



USER'S MANUAL

SIGNAL ISOLATOR

MODEL NUMBER: EU-10098

INVENTORY NUMBER: EUU-7-10098000

DYNAPOWER CORPORATION
85 MEADOWLAND DRIVE
SOUTH BURLINGTON, VERMONT 05403

PHONE: 802-860-7200

TOLL FREE: 800-292-6792

FAX: 802-652-1371

www.dynapower.com

techsupport@dynapower.com

CONTENTS

1	Specifications
2	Description
3	Connector Figures

Word File: 098000M.DOC
Original: January 1992
Revised January 1996

1. SPECIFICATIONS

Input Power	115 Vac, 50/60 Hz
Input Signal	0 - 5 Vdc
Input Resistance	10K ohm shunted by .22 uf
Output	0 - 5 Vdc, 5 ma
Gain8
Isolation	2500 Vdc
Linearity	better than 1%
Step Response	5 ms
Clamp Input	12 Vdc, 1 ma
Size	5" x 5"

2. GENERAL DESCRIPTION

EUC-7-100980000

SIGNAL ISOLATOR

MODEL EU-10098

The EU-10098 Signal Isolator has been designed to isolate and interface remote voltage sources to Dynapower drive circuits.

The purpose of the Isolator is the elimination of ground loops.

Most Dynapower drive circuits require a reference voltage of ≈ 2.5 Vdc into the control inputs. Provision must be made to scale remote signals down to this level. A convenient method is to install a 5000 ohm potentiometer between the output of the Isolator and the drive circuit. If the supplied remote voltage is ≈ 2.5 volts, then this potentiometer is not necessary.

If the input to the Isolator is larger than 5 volts, then the signal must be scaled down by connecting a resistor in series with one of the input lines. The input resistance of the Isolator is 10000 ohms. The value of the dropping resistor is found by:

$$R = (V_{in} - 2.5) \times 10000 / 2.5$$

This should give a voltage of ≈ 2.5 volts.

The adjustment potentiometer is not necessary.

Provision has been made to clamp the isolator output to zero in response to an 'clamp' signal from the drive circuit. This signal from the drive circuit goes high for ≈ 3 seconds when the drive circuit is powered up or when the drive circuit senses an overcurrent fault.

EU-10098 USED WITH CURRENT LOOPS

Current loop signals are sometimes used to supply reference voltages to Dynapower drive circuits. The EU-10098 can be used to isolate the current loop from the drive circuit.

A resistor is connected across the input terminals of the Isolator. The resistor is chosen to give a 2.5 volt drop when the maximum loop current passes through the resistor. If the minimum loop current is not zero, then output of the Isolator will also not be zero. The result is that the drive circuit cannot be shut off with minimum current loop input.

The offset can be removed by the circuit shown.

3. CONNECTOR FIGURES

FIGURE 1: TYPICAL EU-10098 CONNECTION

FIGURE 2 : HIGH SIGNAL EU-10098 CONNECTION

FIGURE 3 : CURRENT LOOP CONNECTION TO EU-10098

FIGURE 4 : CURRENT LOOP CONNECTION TO EU-10098 WITH 4 MA OFFSET
REMOVED

FIGURE 1 TYPICAL EU-10098 CONNECTION

FIGURE 1

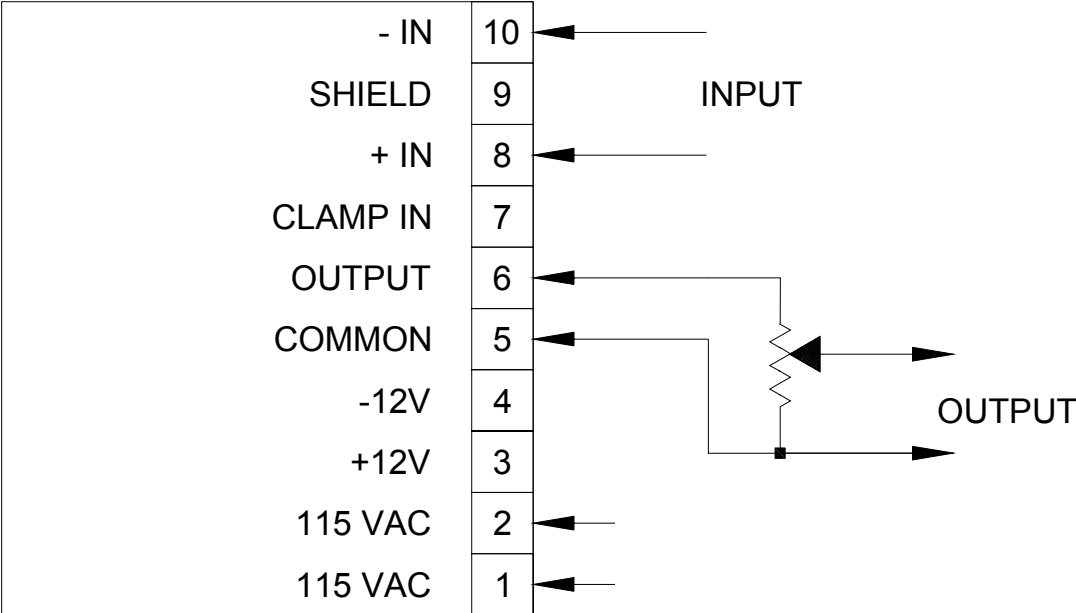

EU-10098 TYPICAL CONNECTION

FIGURE 2 HIGH SIGNAL EU-10098 CONNECTION

FIGURE 2

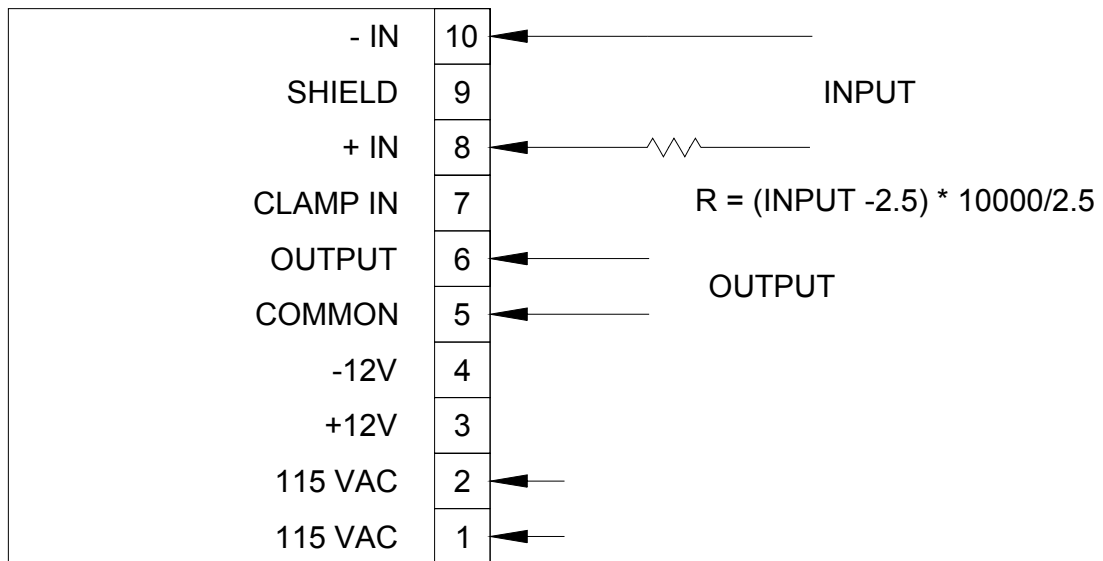

EU-10098 HIGH SIGNAL CONNECTION

FIGURE 3 CURRENT LOOP CONNECTION TO EU-10098

FIGURE 3

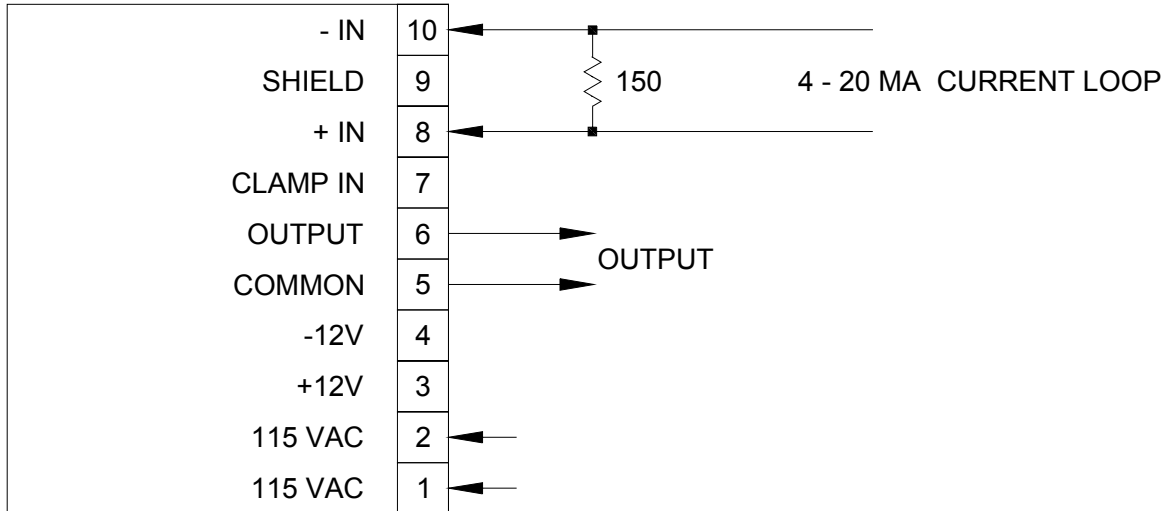

EU-10098 CURRENT LOOP CONNECTION

FIGURE 4 CURRENT LOOP CONNECTION TO EU-10098 WITH 4MA OFFSET

REMOVED

